

TOOLING  
SYSTEMS

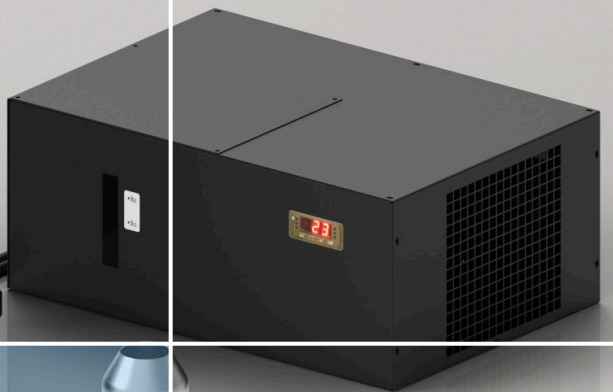

# EASYSHRINK® EVO USER INSTRUCTIONS

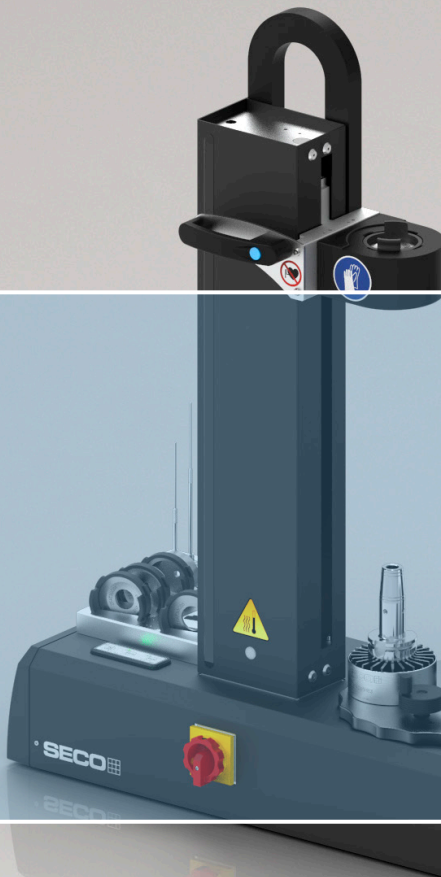
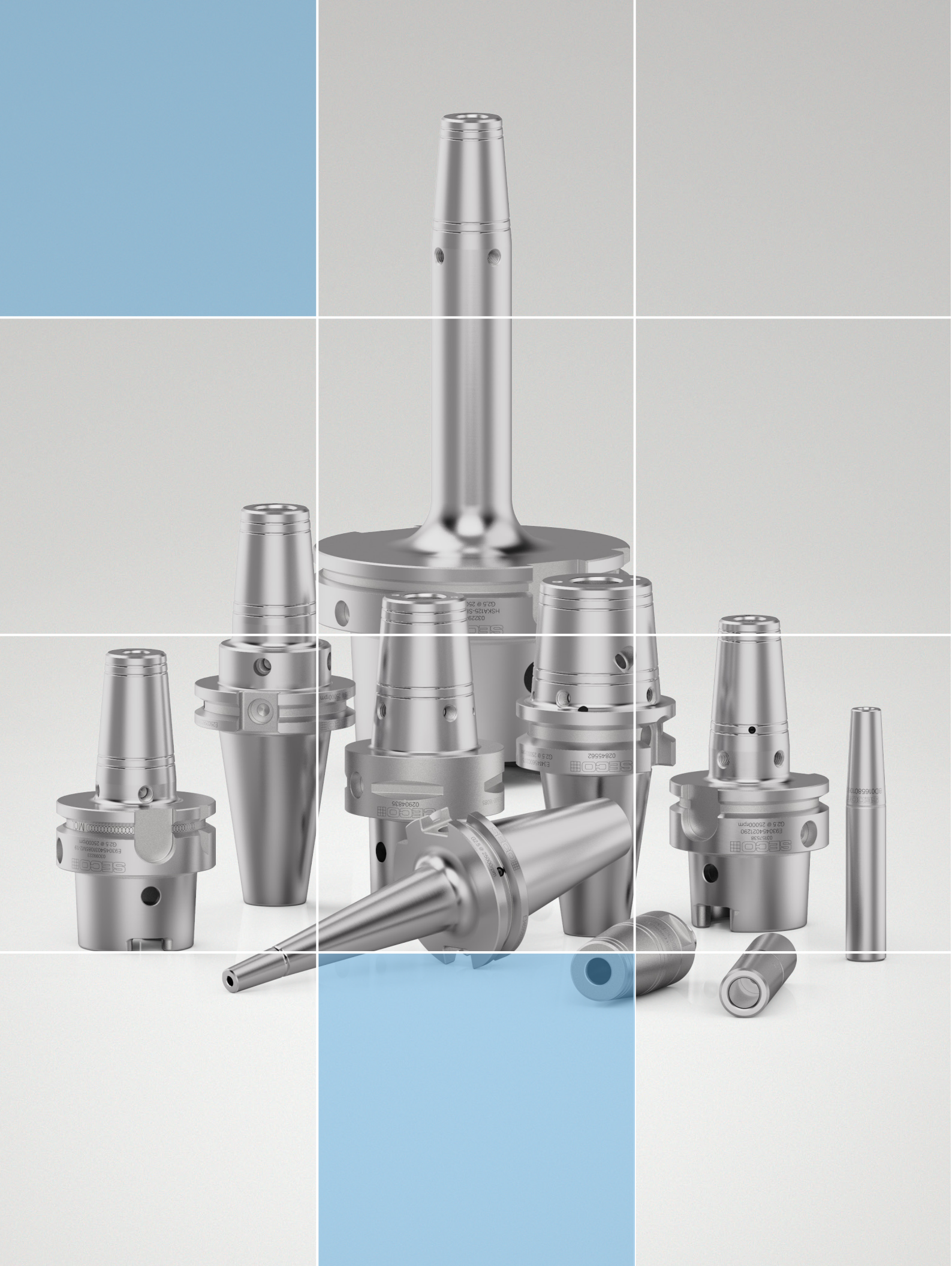

# DEAR CUSTOMER

We thank you for purchasing an **Easyshrink Evo** device.

This induction shrinking device offers you a lot of benefits:

- User-friendly: Automatic or manual heating cycles, simple interface, ergonomic and easy to use control interface.
- Quick shrinking and unshrinking of steel, high speed steel, heavy metal and carbide tools\*.
- Localized and homogeneous heating of the clamping area
- Minimal energy consumption
- Fast cooling of the tool and the toolholder

This operating manual will give you all the necessary information to use this device in the best way.

Our sales team is at your full disposal if you need further clarification.

Your Partner,  
Seco Tools

\* This device was optimized to be used with all standard Seco Tools toolholders. Other branded toolholders need to be configured and validated.

## PROVISIONS OF WARRANTY

If your product proves to be defective even if it has been used properly (in accordance with the written operating instruction manual supplied with it) within a period of 24 months from the date of invoicing, this product will be repaired or replaced free of charge.

This warranty covers material defects. Any defect that occurs due to mishandling that is not mentioned in the operating instruction manual or is due to improper maintenance, etc. is not covered. Seco Tools' sole liability is limited to repairing or replacing the product. Any liability for indirect or consequential loss or damage of any kind incurred or suffered by the customer due to a product defect is excluded.

# IMPORTANT CAUTIONS & WARNINGS

The Easyshrink Evo is built with the latest technology and it is extremely safe and easy to operate.

However, there is still some danger if this device is operated incorrectly and/or by untrained personnel.

Pay particular attention to the following cautions and warnings marked with the “Attention” and “Danger” symbols.

Failure to follow safe operating practices may cause injuries, death or damage to the device and may VOID your manufacturer's warranties.



- Before attempting to use the device, you must read and fully understand this User Guide. Keep this User Guide within easy reach of operating personnel.
- Visually inspect the device, power cord and accessory items for any signs of wear or damage before operating the device. Do not use the device if there is any sign of damage or if the device is not performing normally.
- Never operate the device without the correct induction heat-focusing stopper in place on the induction head. Do not allow any part of the induction head to contact the tool holder or cutting tool during operation or damage to the device may occur.
- The holder and the tool must be clean, free from grease and dry before being fitted to the device.

- Tool shank tolerance required: Ø3 to 5 mm (Ø0.118” to 0.1968”) maximum h5. Tool shank must be carbide or heavy metal (e.g. Densimet). Ø6 to Ø32 mm (Ø0.236” to Ø 1.25”) maximum h6. Tool shank can be steel, HSS, carbide or heavy metal. Using h5 for Ø6 to Ø32 mm (Ø0.236” to Ø1.2598”) provides a safer minimum clamping torque.
- Do not wear rings, bracelets or other metallic objects while operating the device. Metallic objects may heat up very quickly when near the induction head during operation.



- Use the provided heat-resistant gloves and pliers whenever handling tools or tool holders. Never try to handle hot tools or tool holders until the cooling cycle is complete.
- If the device is moved from a cold environment to a warm one, wait three hours before operating to prevent build-up of condensation and electronic system errors.
- **Persons with pacemakers fitted may not operate the device and must maintain a minimum safe distance of 2 meters (6 feet) from the device at all times.**
- Cutting tools have sharp edges. Handle with caution.



- The power cord provided must be plugged into the correct standard, three-phase outlet for your country. Operating the device while it is improperly connected or at the wrong voltage may damage the device and could cause death or injury.
- Position the power cord so that it cannot be damaged by fork trucks or other equipment or cause a tripping hazard for personnel.
- Do not operate the device in a wet environment where exposure to coolant or spills are likely to occur. Electric shocks or damage to the device may occur.
- Never operate the device around flammable materials or fumes. Do not use flammable liquids or aerosols to clean the tool holders. Never expose the device or hot tools to combustible materials.
- Never open the device or attempt repairs or you will VOID the manufacturer’s warranty. There is dangerous residual voltage inside that may cause death or injury.
- Unauthorized modifications or changes to the Shrinkfit Evo device will VOID your manufacturer’s warranty. Do not try and service your device yourself. After-sales technicians can provide any necessary repairs or maintenance. Do not modify or disable the built-in safety features of the device.
- Turn off the power switch and disconnect the power cord from the outlet before cleaning, servicing or storing the device.



# CONTENT

Device general overview .....	6
Accessories and spare parts .....	7
Easyshrink Evo features .....	8
Range overview.....	9
Refrigeration unit .....	9
Refrigerated water-cooling bells unit.....	10-13
Shrinking principle.....	14
Taking delivery.....	15
Working environment of the device .....	15
Keypad and display presentation	16
Starting the device .....	16

Starting to shrink and unshrink...	17
Shrinking depths to be respected	17
Stop rod selection .....	18
Mode selection .....	19
Shrinkfit.....	20
Shrink release.....	22
Audible feedback .....	22
Boost mode.....	22
Shrinkfit of special tool holders...	23
Shrink release of special tool holders .....	25
Shrinking capability.....	26
Maintenance frequency .....	27

Safety precautions .....	28
Annexes .....	28
Technical features .....	29
Compliance statements .....	30-31

# GENERAL OVERVIEW

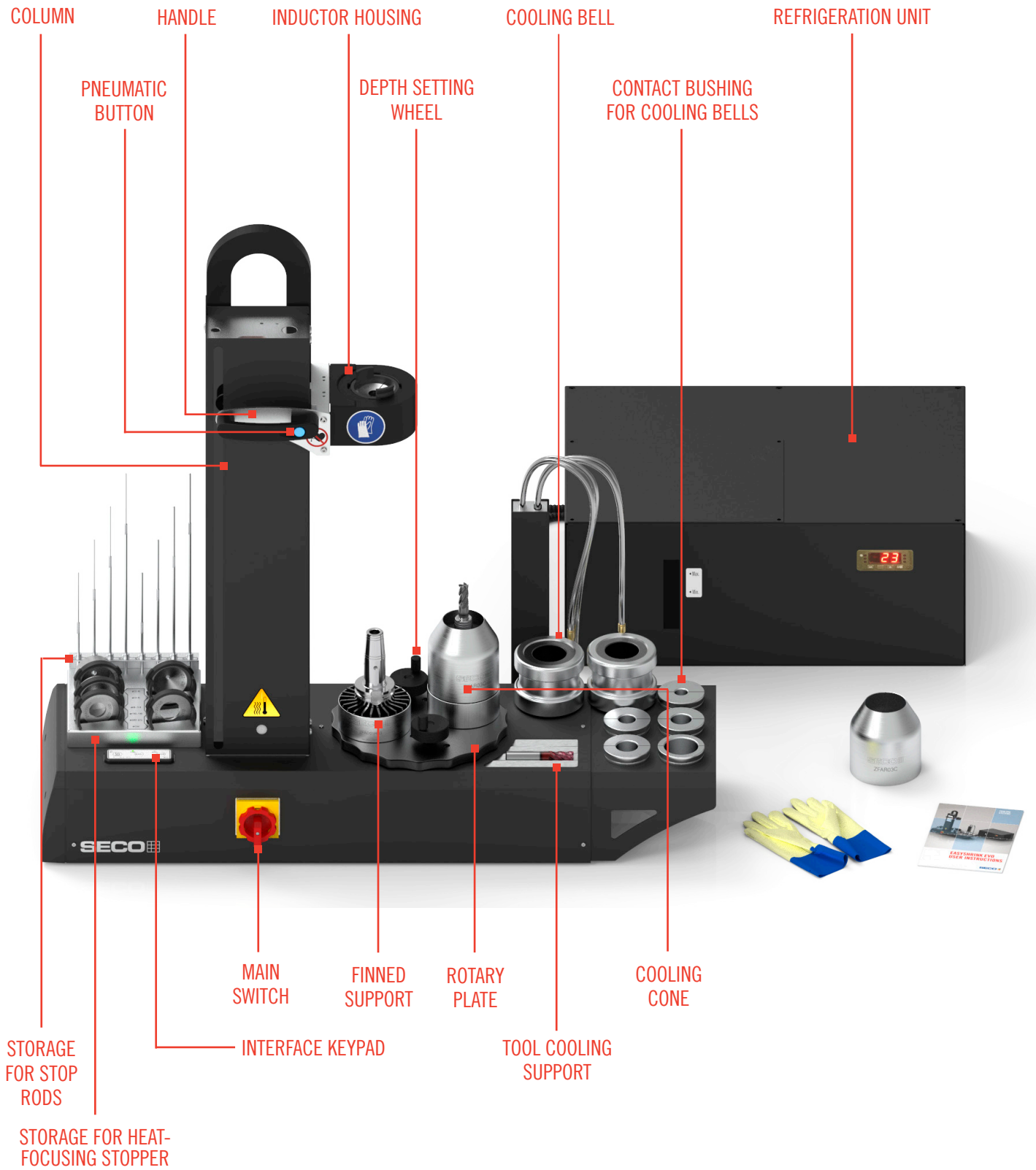

## ACCESSORIES AND SPARE PARTS

**Important:** These accessories related to the Shrinkfit tool holders must be ordered separately in order to use the Easyshrink EVO.

### REQUIRED AS A MINIMUM FOR SHRINK GRIP AND SHRINK RELEASE OPERATIONS

- Finned supports for each type of machine side taper used on Shrinkfit tool holders. Available for all types of tool holder (HSK / DIN & DIN TF / BT & BT TF / CAT & CAT TF / Capto).

Provides positioning of the tool holder onto the support module.



Finned support

### REQUIRED AS A MINIMUM FOR THE WATER COOLER

- Contact bushing for each type and size of Shrinkfit tool holder used. Available for all types of Shrinkfit holders and diameters (DIN type / Reinforced / Mold and Die / MQL)

Required to extract heat from the front end of the holder towards the liquid cooling bell.



Contact bushing

### SPARE PARTS

- Set of standard and thin stop rods. 4 stop rods with 2.5 mm (0.098") front end and 4 stop rods with 5 mm (0.197") front end covering a shrink depth capacity of 0 to 240 mm (0 to 9.45"):  
0-60 mm (0-2.36") / 60-120 mm (2.36-4.72") / 120-180 mm (4.72-7.09") / 180-240 mm (7.09-9.45").

Enables the tool shrinking depth setting and ejection of broken tools.

- Air cooling cones.

Directs the air stream against the front end of the holder for cooling



Set of stop rods



Air cooling cone

- Heat-focusing stoppers. Available for shrinking and unshrinking tool holders  $\text{Ø}3$  to  $\text{Ø}32$  mm ( $\text{Ø}0.118$ " to  $\text{Ø}1.26$ ").

Magnetic insulator that allows the magnetic field to be concentrated on the front part of the tool holder and to achieve optimised heating.



Standard heat-focusing stopper

- Split heat-focusing stoppers. For the split heat-focusing stopper, a locking ring must be ordered.

Split magnetic insulator that allows the magnetic field to be concentrated on the front part of the tool holder and to achieve optimised heating of tools with a front end that is larger than shank.

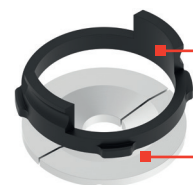

Pair of split heat-focusing stopper and ring

LOCKING RING

HALF HEAT-FOCUSING STOPPER

# EASYSHRINK EVO FEATURES

## STOP RODS

Different size stop rods are available to easily adjust the depth of your tool in your tool holder

## HEAT-FOCUSING STOPPERS

Enable the shrinking or unshrinking of carbide or HSS tools Ø3 to Ø32 mm (0.118" to 1.260").  
NB: Split heat-focusing stoppers available as accessories for larger head tools.

## INDUCTOR

Fast and optimized cycle for shrinking and unshrinking steel, HSS, heavy metal or carbide tools with Seco Tools holders

## COLUMN

Enables the shrinking and unshrinking of tool holders with a maximum length of:

- 480 mm (18.897") with HSK-32 finned support
- 430 mm (16.930") with SA50 finned support
- 490 mm (19.290") with other finned support



## SMART

- Small computer that enables a smart web interface through a Wi-Fi connection or by RJ45
- TDM Systems compatible
- Special program is easily programmable
- Global view of the system status

## INTERFACE

- Simple control panel with LED indicator
- 3 standard programs for all Seco Tools holders
- 1 programmable mode for other tool holders (specific shape or competitors)
- 1 manual mode

## ROTARY PLATE WITH SHRINK DEPTH SETTING

- Allows the operator to switch the hot tool holder from the heating position to the cooling position without any contact with the hot tool holder
- Allows the operator to adjust the depth of your cutting tool using a height-adjusting knob that moves the stop rods



## RANGE OVERVIEW

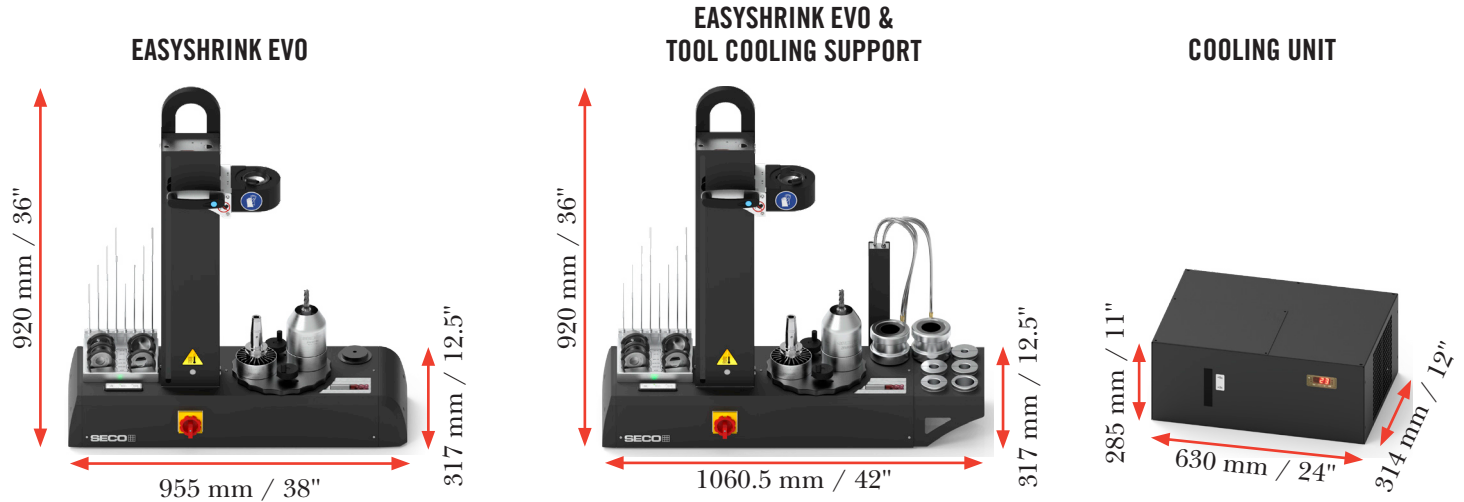

## EASYSHRINK EVO

### FEATURES

- Power: 20 kW allows the shrinking and unshrinking of tools  $\varnothing 3$  to  $\varnothing 32$  mm ( $\varnothing 0.118$ " to  $\varnothing 1.26$ " )
- Max. tool length: 430 to 490mm
- Max. machine interface: HSK-A125
- Dimensions (W x D x H): 317 x 955 x 920 mm / 12.5" x 38" x 36"
- Cooling time:  $\pm 7$  minutes with cooling cones
- Weight: 46.2 kg (102 lbs)

### DELIVERY CONTENT

- 5 standard heat-focusing stoppers for  $\varnothing 3$  to  $\varnothing 32$  mm ( $\varnothing 0.118$ " to  $\varnothing 1.26$ " )
- 8 stop rods
- 2 cooling cones
- 1 pair of gloves
- 1 operating instructions

### CONNECTIONS

The device only accepts the voltage AC 3 x 400 V (+/-10%) + PE/28 A/50 Hz  
**For other voltages the use of a ZFM30IN30 transformer is required, which needs to be bought separately (CSA approved transformer needed for Canadian market):**

- Input voltages: 3 x 208 / 240 / 480 / 600 VAC + GND/28 amp/50-60 Hz
- Output voltages: AC 3 x 400 V + PE/28 A/50 Hz
- 3 meters (10 ft) cable is supplied
- Incoming air supply 3 to 6 bars (43 to 87 psi)/pipe  $\varnothing 10$  mm ( $\varnothing 0.393$ " ) required

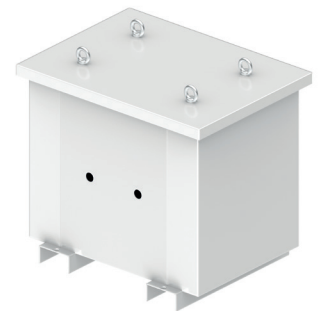

## OPTIONAL PRODUCT

### REFRIGERATION UNIT

#### FEATURES

- Cooling time:  $\pm 1$  minutes
- Extension table: Allow storage of 5 contact bushing and 1 cooling bell
- Weight: 39.8 kg (88 lbs)

#### DELIVERY CONTENT

- Refrigeration unit
- Tube support
- 2 bells
- Extension table



## REFRIGERATED WATER COOLING BELLS UNIT

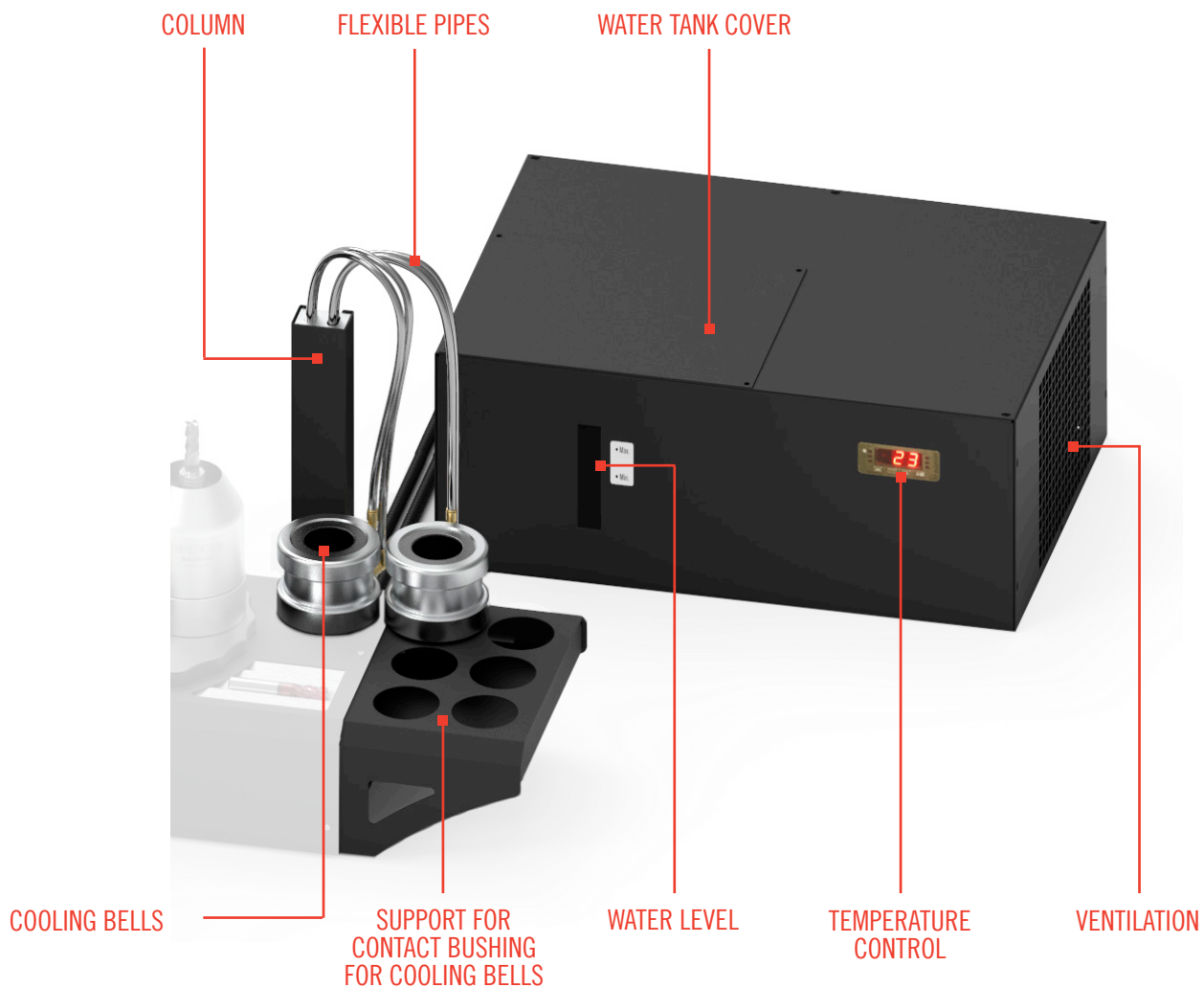

## INSTALLATION OF THE REFRIGERATION UNIT



The water cooler must be positioned on a stable working platform with a clearance of 50 cm (19.7") on both sides in order to allow air flow.

## MOUNTING THE EXTENSION TABLE

(AVAILABLE AS AN ACCESSORY OR DELIVERED WITH THE WATER-COOLING OPTION)

Tighten the 2 screws **1**.

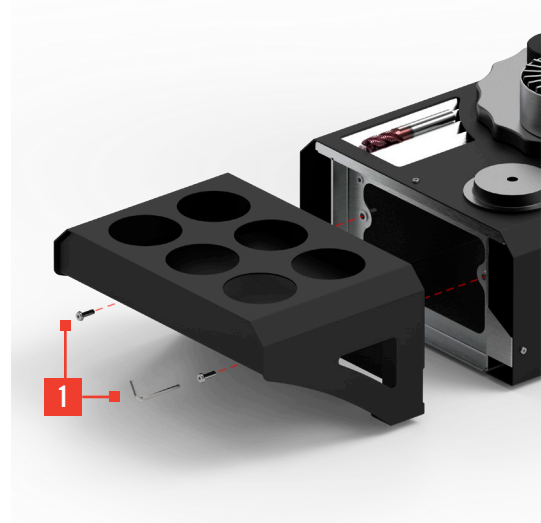

## MOUNTING THE COLUMN FOR THE WATER-COOLING TUBES

(DELIVERED WITH THE WATER-COOLING OPTION)

Tighten the 4 screws **2**.

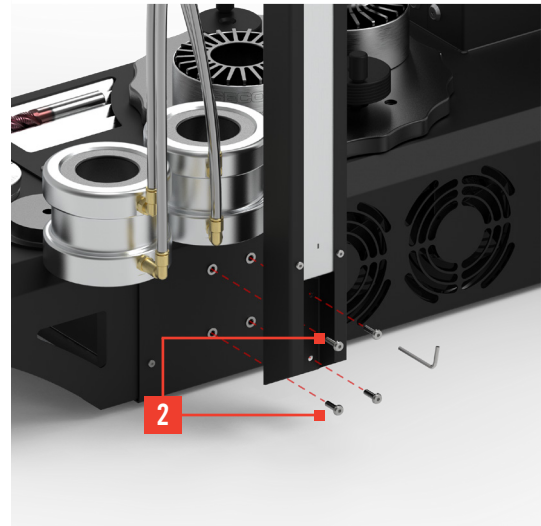

Connect the 2 tubes **3** of the water-cooling system to the connectors of the column.

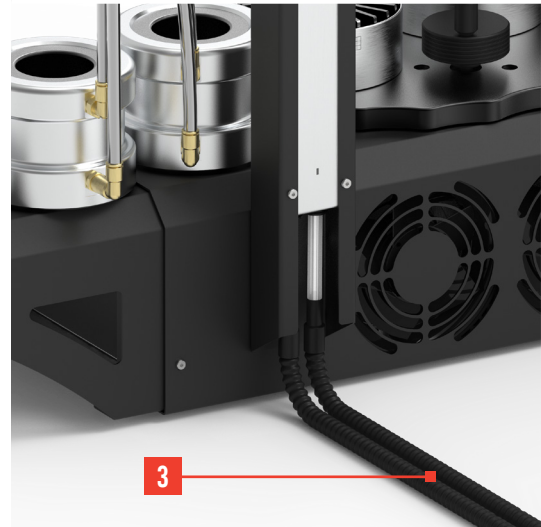

## FILLING THE COOLER

Open the cover on the top of the cooler (4 screws to release) **4**.

Fill in the tank with pure water until the indicator shows you that the tank is full.

Tap water:  $7.5 < \text{pH} < 9$  /  $7^{\circ}\text{C}$  ( $44.6^{\circ}\text{F}$ )  $< \text{TH} < 15^{\circ}\text{C}$  ( $59^{\circ}\text{F}$ )

Note: change the water approx. every 6 months.

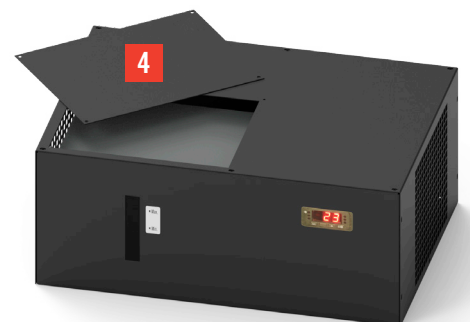

## CONNECT THE REFRIGERATED UNIT TO THE EASYSHRINK EVO

Plug the cable from the refrigerated unit into the outlet **5**.



Never turn on the power without having filled the cooler first. After first use, it might be necessary to add more water to the tank (check the level). Afterwards, a regular check of the water level and quality is recommended.

## WATER TEMPERATURE SETTING

When the power is turned on, the water cooler displays « -88 » for 3 seconds and then displays the temperature of the water.

The water temperature is preset in our plant at +20°C (68°F).

It is adjustable from 10°C to 25°C (50°F to 77°F) **6**.



In the case of noticeable condensation, it is recommended to set the water temperature higher.

To see the preset temperature, press the SET button **7**.

To modify the preset temperature, simultaneously press SET and « up arrow » or « down arrow » **8**.

As soon as the SET button is released, the water temperature is displayed.

The temperature varies between « preset temperature » and « preset temperature + 2° C (35.6°F) ».

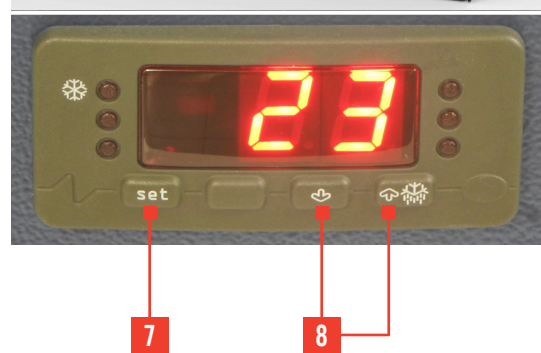

## USE

Install the corresponding contact bushing **9** for the cooling bells (Ø and holder type depending) onto the top of the holder, and slip over the cooling bell **10**.

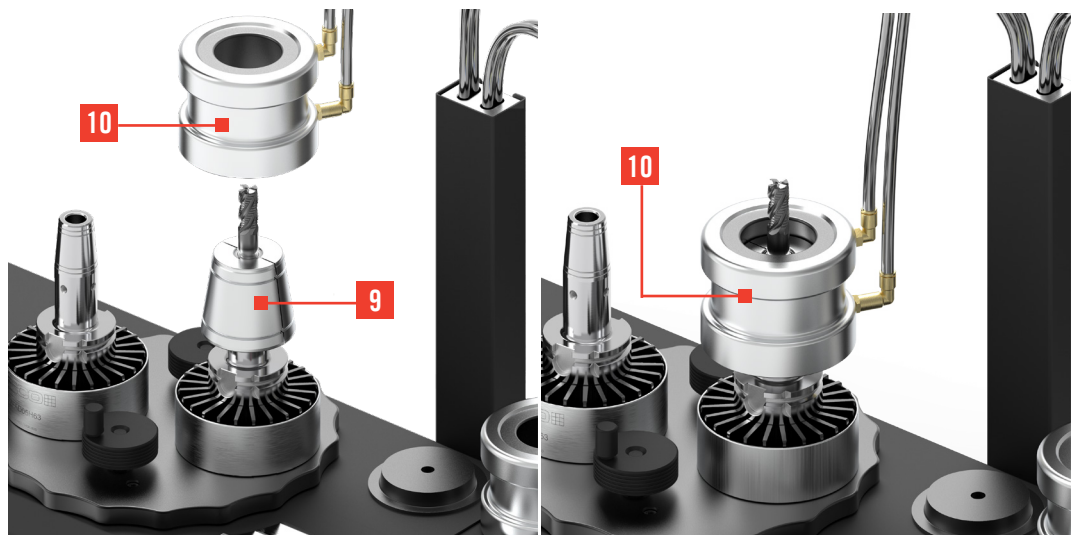

# WATER COOLER MAINTENANCE

	FREQUENCY	OBSERVATION
WATER LEVEL CHECK	1 month	
WATER TANK CHECK	6 months	Water ( $7.5 < \text{pH} < 9$ and $7^{\circ}\text{C} (44.6^{\circ}\text{F}) < \text{TH} < 15^{\circ}\text{C} (59^{\circ}\text{F})$ )
RADIATOR CLEANING	2 months	Do not use an air blower

## REMARKS

- The tank must only be filled up with pure water (tap water, please refer to recommendations in the table above) and any other product is forbidden (distilled water, demineralised water, glycol etc.).
- If the water cooler will be idle for a long period, the device must be stored in an area at an ambient temperature to avoid any risk of frost.
- Repairs to the refrigeration unit must only be carried out by qualified heating and cooling expert.
- The water cooler must not run with an empty tank.

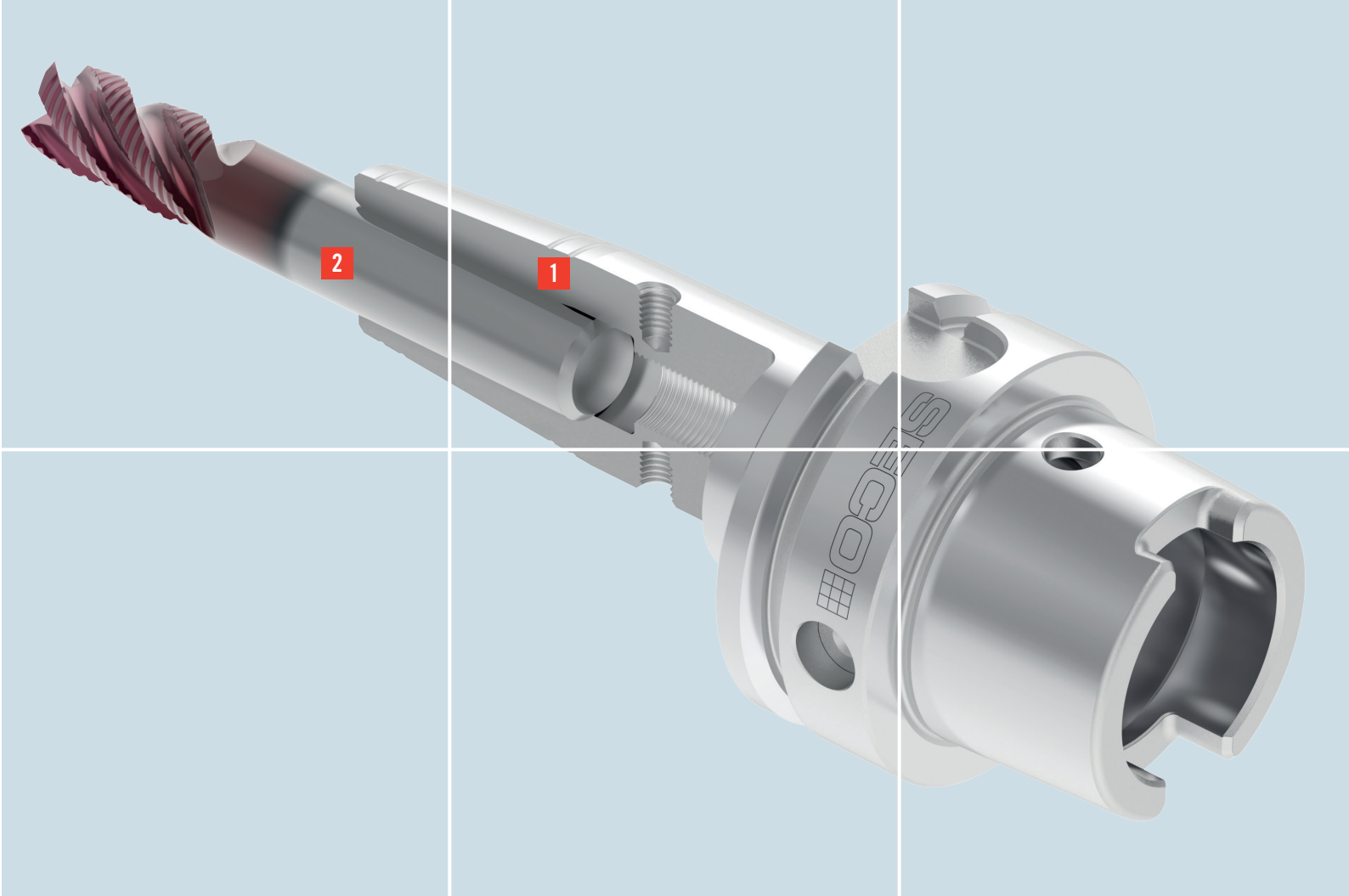

## SHRINKING PRINCIPLE

The Shrinkfit holder's internal diameter **1** is designed to be slightly smaller than the shank diameter **2** of the cutting tool. When placed into the induction heating system, the inside bore is heated and expands. The tool shank can then be slipped easily into the holder. As the holder cools down, the resulting thermal contraction exerts a tremendous, uniform pressure around the entire surface of the tool shank.

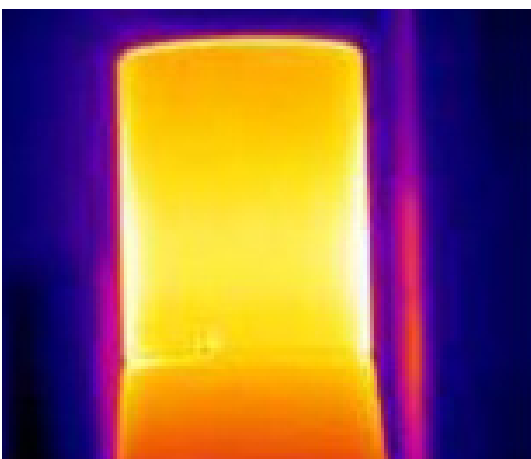

## INDUCTION

The induction heating allows tools to be clamped in a few seconds. A high magnetic field flux is created and remains concentrated on the clamping area. This means that less energy remains in the holder and the cooling time is reduced. This allows the HSS tools to be unshrunk with the same thermal expansion coefficients as the steel used for the holders.

## TAKING DELIVERY

The device you have received has been controlled and tested in our plant according to ISO9001 specifications. If the equipment is being stored or transported under unacceptable conditions it may be permanently damaged. In this case the manufacturer will exclude all warranty claims and obligations. Unpacking must be carried out carefully to avoid any damage. A tilt-watch indicator is positioned on the packaging to guaranty the pallet has not been tipped over.

## WORKING ENVIRONMENT OF THE DEVICE

The Easyshrink Evo device needs to be positioned in a dry and clean working area on a stable and rigid surface that is resistant to hot tool holders (+/-100°C (212°F)).

### CONNECTIONS

**Remark:** The transformer for voltages in the USA or Canada is available as an optional accessory.

#### ▪ Power supply:

The device only accepts the voltage AC 3 x 400 V (+/-10) + PE/28 A/50 Hz

**For other voltages the use of a ZFM30IN30 transformer is required, which needs to be bought separately (CSA approved transformer needed for Canadian market):**

- Input voltages: 3 x 208 / 240 / 480 / 600 VAC + GND/28 amp/50-60 Hz
- Output voltages: AC 3 x 400 V + PE/28 A/50 Hz

#### ▪ Air supply:

- 3 to 6 bar (43 to 87 psi)/pipe external Ø10 mm (Ø0.393") (pipe not supplied)
- 3 meters (10 foot) cable is supplied

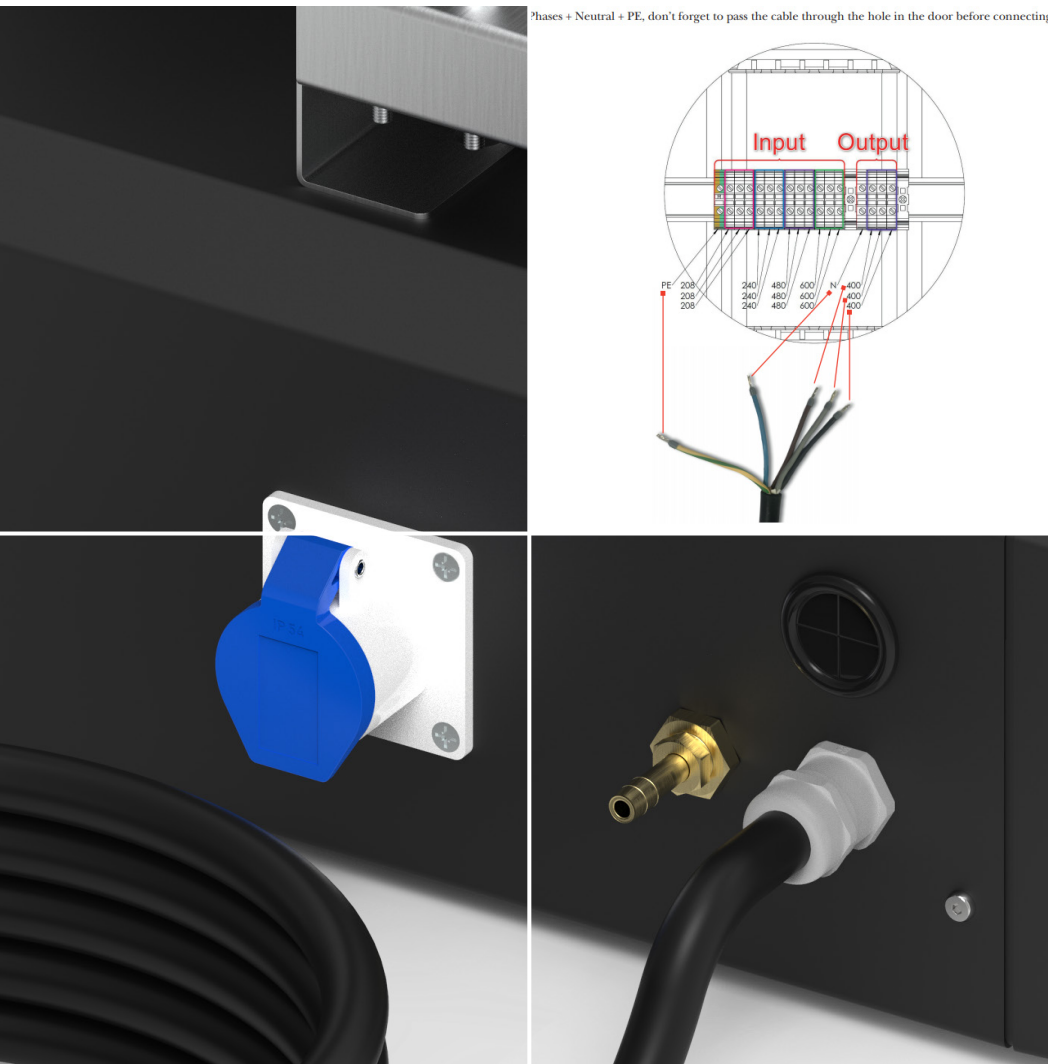

# KEYPAD AND DISPLAY PRESENTATION

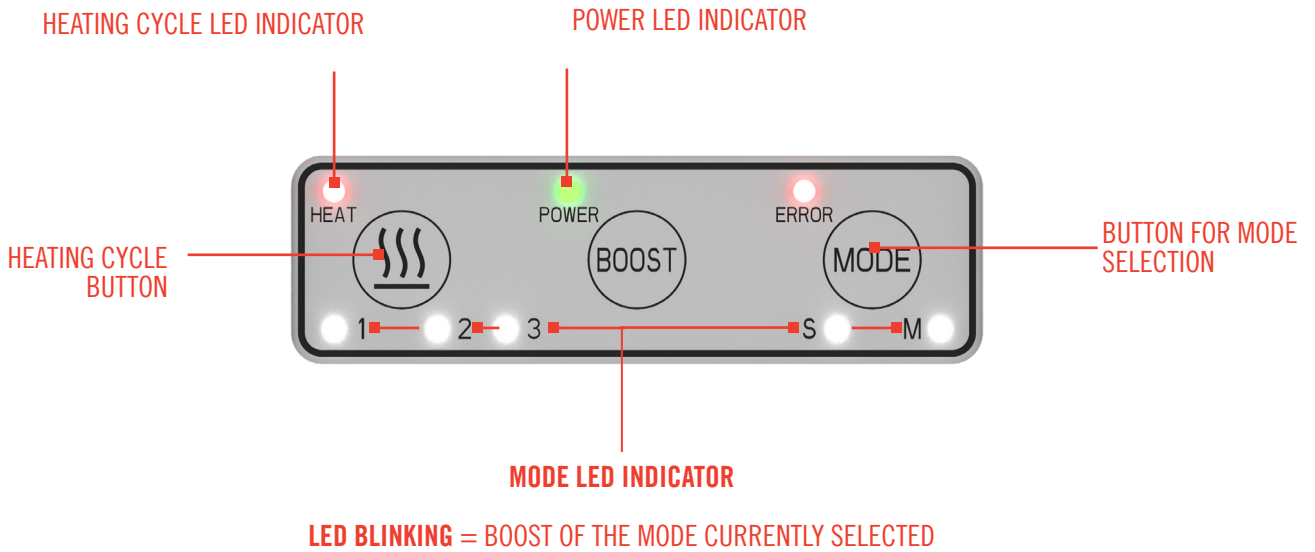

## STARTING THE DEVICE

**1 2** Switch ON the main interrupter of the Shrinkfit device.

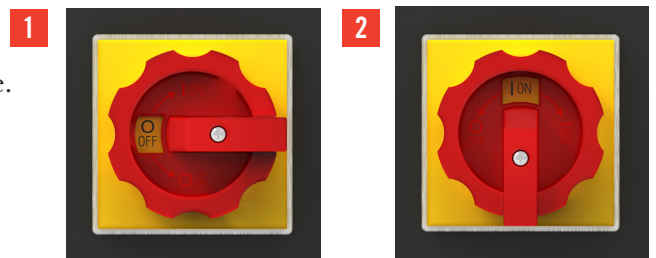

**3** The Power LED turn ON.

**4** After 10 seconds, the Power Led and Mode 1 LED are activated and show that the device is ready to be operated.

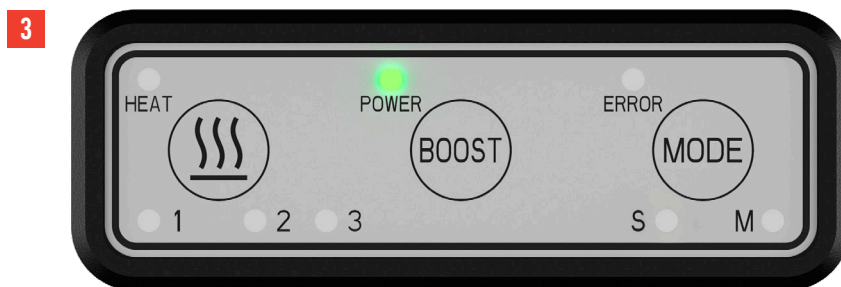



## STARTING TO SHRINK AND UNSHRINK



Always wear protective gloves while handling Shrinkfit holders, tools, accessories and spare parts.



Electrical hazard when dismantling module parts



Persons with medical implants are not permitted to use or work with this device. Persons with a pacemaker must refer to the guidelines for their pacemaker established on the basis of: NF EN 60601-1-2 (September 2017)



**Do not use hydraulic tool holders on this device as there is a risk of explosion and third-degree burns. Please notify and provide training to operators who may use this device.**

### SHRINKFIT TOOL HOLDER & CUTTING TOOLS

The Easyshrink Evo device makes it easy and safe to perform Shrinkfit tool changes without causing damage to the toolholder or cutting tool, as long as the device is correctly installed and the operating procedures are followed.

Easyshrink Evo is designed to work best with all standard SECO Shrinkfit toolholders and efficiently with tools made from steel, HSS, heavy metal or carbide.

#### Tool shank diameter tolerance is critical.

Tool shank tolerance required:

Ø3 to Ø 5 mm (Ø0.11" to Ø0.19") maximum h5, tool shank must be carbide or heavy metal (e.g. Densimet).

Ø6 to Ø32 mm (Ø0.23" to Ø1.25") maximum h6, tool shank can be steel, HSS, carbide or heavy metal.

Using h5 for Ø6 to Ø32 mm (Ø0.23" to Ø1.25") provides a safer minimum clamping torque.

Make sure the minimum shrinking depth LSC shown in the Product pages for each holder is respected when fitting the tool shank into the holder.

Make sure that the toolholders and the tools are clean, free from grease and dry before being fitted in the device.

### SHRINKING DEPTHS TO BE RESPECTED

We recommend the following shrinking depth in order to guarantee the minimum transmittable torque and lifetime of the tool.

#### EXAMPLE FOR A TYPE SFD 5403 SECO TOOL HOLDER:

The diameter **DCBX** (tool-fitting size) is indicated in the toolholder specification.

The shrinking depth (depending on the position of the stop end screw) must be set to **LSC** as a minimum.

In this case, the chart indicates **LSC = 39 mm (1.54")**

#### MINIMUM SHRINKING DEPTH

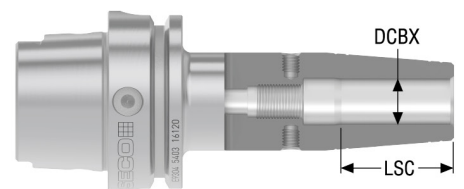

Metric		Inch	
DCBX	LSC Min	DCBX	LSC Min
3	13	1/8"	1/2"
4	15	-	-
5	18	3/16"	3/4"
6	26	1/4"	7/8"
8	30	5/16"	1"3/16
10	32	3/8"	1"4/4
12	34	1/2"	1"3/8
14	34	-	-
16	39	5/8"	1"1/2
18	39	3/4"	1"5/8
20	42	7/8"	1"5/8
25	47	1"	1"7/8
32	52	1" 1/4	2"

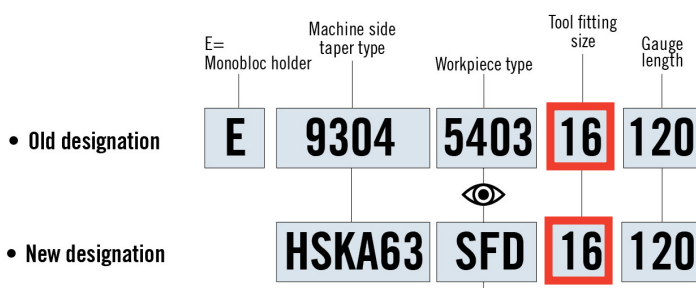

# STOP ROD SELECTION

**STOP ROD SELECTION**

$LFNLF = LPR - LSC$

Stop rod selection	Metric LFNLF	
	Min	Max
<b>S1</b>	0	60
<b>S2</b>	60	120
<b>S3</b>	120	180
<b>S4</b>	180	240

Stop rod selection	Inch LFNLF	
	Min	Max
<b>S1</b>	0	2 <sup>3</sup> / <sub>8</sub>
<b>S2</b>	2 <sup>3</sup> / <sub>8</sub>	4 <sup>3</sup> / <sub>4</sub>
<b>S3</b>	4 <sup>3</sup> / <sub>4</sub>	7 <sup>1</sup> / <sub>16</sub>
<b>S4</b>	7 <sup>1</sup> / <sub>16</sub>	9 <sup>7</sup> / <sub>16</sub>

The stop rods enable:

- The depth of the tool inside a tool holder without back-up screw to be set
- The depth of the tool for twin tool holders for multi-spindle machines to be set
- Broken tools stuck inside a tool holder to be pulled out

## NOTE

The stop rod is chosen by the LFNLF (= LPR - LSC) result and your value will correspond to a specific **S** Group. When using finned support for Shrinkfit holder taper SA50 (ZFAD05S50), add 60 mm to the LFNLF value obtained.

**Example:** Seco Tools tool holder type SFD 5403









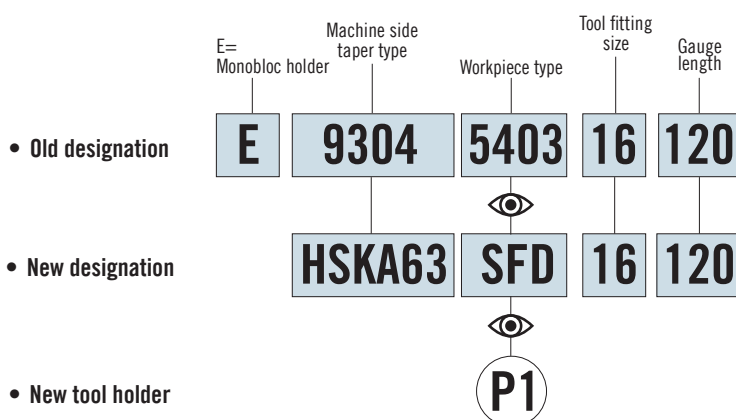

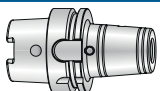

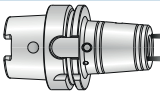

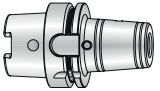

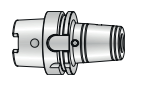
We have previously determined that the shrinking depth LSC = 39 mm (1.54"). The gauge length LPR can be found by reading the specification or by measuring.

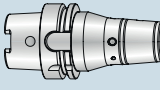
$$LFN-LF = LPR - LSC = 120 (4.72") - 39 (1.54") = 81 \text{ mm } (3.18")$$

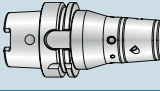
In this case, the suitable stop rod is the one in front of the **S2**.

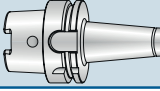
## HEATING MODE SELECTION ACCORDING TO MARKING OF:

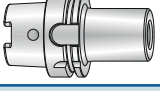

Workpiece type	Old designation	New designation	Symbol	Mode	Normal
	5403 5603	SFD	(P1)	1	
	5402 5602	SFD...-L1	(P1)	1	
	5403M 5403M1 5403M2	SFD...M SFD...M1 SFD...M2	(P1)	1	
	SPECIAL SHORT*	SPECIAL SHORT*	(PS)	1	
	5600	SFR	(P2)	2	
	5600P Safe-Lock™	SFR	(P2)	2	
	5801	SFS	(P2)	2	
	5800	SFD...-F6	(P3)	3	
Custom tool holders	Special program	Special program	/	S	

\* Short tool holders for tools  $\varnothing 3$  to  $\varnothing 8$  mm, with V-flange surrounded by the inductor:  
Use special heat focusing plate ZFAT30C06.

Immediately move up the inductor after each heating cycle.

## SHRINKING PROCESS

**1** Choose the tool holder finned support that corresponds to your tool holder

**2** Select the corresponding heating mode to use with help of the specification located on the flange and the table above

**3** Place the finned support on the rotary plate hole

**4** Take the heat-focusing stopper corresponding to your tool shank diameter and place it in the inductor.

Secure the heat-focusing stopper by turning the heat-focusing stopper a quarter turn into the inductor

### NOTE

Only use ZFAT30C06 for special short tool holders. More details on the "Heating Mode Selection" sticker.





# SHRINK RELEASE

The unshrinking process is the same as the shrinking process.

# AUDIBLE FEEDBACK

During operation, the device power source generates an audible feedback tone that changes frequency depending on the tool holder size and temperature.

It is not unusual to hear the pitch change as the tool holder temperature increases.

Do not be alarmed if you hear this tone, as it is normal.

# BOOST MODE

The boost function was made to avoid issues when:

- The cutter tool falls outside the H5/H6 tolerance band
- There is dirt between tool holder and the tool
- Light overheating of the tool holder
- Competitor's shrink and unshrink toolholders with same shape as our standard shape, but with different tolerance on bore

Before using the Boost function, please ensure that your tool holder is not already hot (<30°C (122°F))

Seco is not responsible for misuse of the Boost function.

The Boost function is only for one cycle

**1** Push the Mode button until you reach the corresponding mode shown earlier in the table.

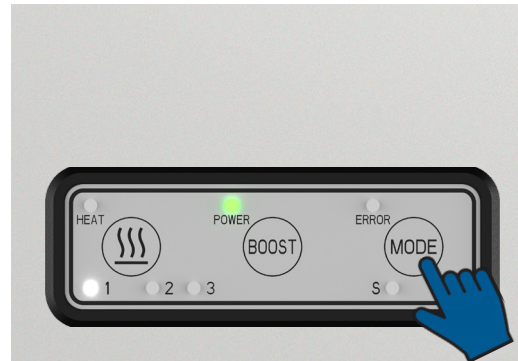

**2** Push the Boost button once and the LED of the selected mode will blink.

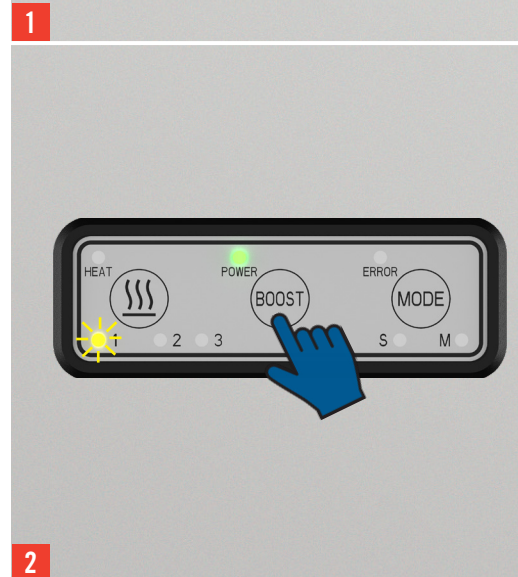

**3** You are ready to start the heating cycle. Follow the same instruction from step 9 of the shrinking process.

The Boost function can be configured in the web interface. The default Boost function increases the heating time by 15%.

## SHRINKING FOR SPECIAL TOOL HOLDERS

For special tool holders, e.g. tools with a front end that is larger than the shank, split heat-focusing stoppers are available. The use of split heat-focusing stoppers requires clearance between the tool head and the front face of the tool holder. To successfully shrink/release special tools, it is necessary to observe the following conditions:

- Maximal diameter of the cutter **BD** is 3 x **BD1**
- $\varnothing$  **BD** maximum =  $\varnothing 63$  mm ( $\varnothing 2.48$ "  
(maximum bore  $\varnothing$  of induction unit)
- **LPR** dimension = 70 mm (2.76") minimum  
(due to the inductor housing dimension)
- **LU** dimension changes depending on the tool shank diameter **BD1**



TOOL SHANK $\varnothing$ MM:	3 (0.12")	4 (0.16")	5 (0.2")	6 (0.24")	8 (0.31")	10 (0.4")	12 (0.47")
LU dimension (mm):	6 (0.24")	6.5 (0.24")	7 (0.27")	7.5 (0.27")	7.5 (0.27")	9 (0.35")	10 (0.39")
TOOL SHANK $\varnothing$ MM:	14 (0.55")	16 (0.63")	18 (0.71")	20 (0.79")	25 (1")	32 (1.26")	
LU dimension (mm):	11.5 (0.43")	10 (0.39")	11.5 (0.27")	12 (0.47")	9 (0.35")	9 (0.35")	

## SHRINKFIT OF SPECIAL TOOL HOLDERS

Insert the split heat-focusing stoppers **1** that match the tool shank  $\varnothing$  (see table on previous page) into the location diameter in the inductor housing.

5 split heat-focusing stoppers covering a tool shank diameter of  $\varnothing 3$ - $\varnothing 32$  ( $\varnothing 0.118$ " to  $\varnothing 1.26$ " are available as accessories with the following capacities:

$\varnothing 3$ - $\varnothing 6$  ( $\varnothing 0.118$ "- $0.236$ " ),  $\varnothing 8$ - $\varnothing 14$  ( $\varnothing 0.314$ "- $0.551$ " ),  $\varnothing 16$ - $\varnothing 18$  ( $\varnothing 0.629$ "- $0.708$ " ),  $\varnothing 20$ - $\varnothing 25$  ( $\varnothing 0.787$ "- $0.984$ " ),  $\varnothing 32$  ( $\varnothing 1.26$ " ).

Fit the lock ring **2** to retain the split heat-focusing stopper in the inductor housing.

Start the heating cycle for a standard tool.

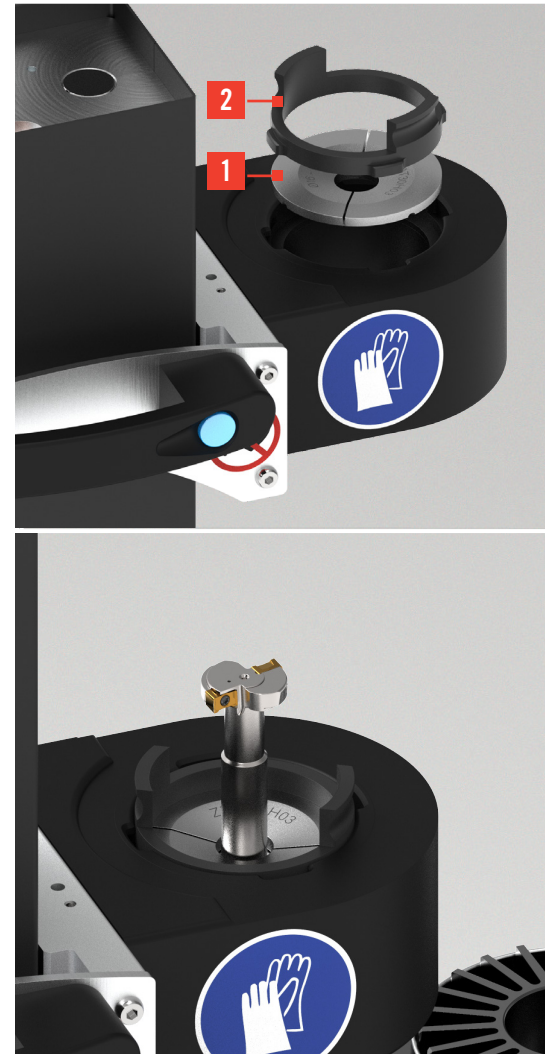

After shrinking remove the lock ring **4** and move the inductor housing downwards **5**, exposing the split heat-focusing stopper.



Remove the split heat-focusing stoppers **6** (caution – it may be hot).



Move the inductor housing **7** upwards to allow the toolholder to be removed.

#### NOTE

The overall height of the inductor housing limits the « LPR » dimension to a minimum of 70 mm (2.76"). Any less than this and it will not be possible to lower the inductor housing sufficiently to gain access to the split heat-focusing stopper assembly.

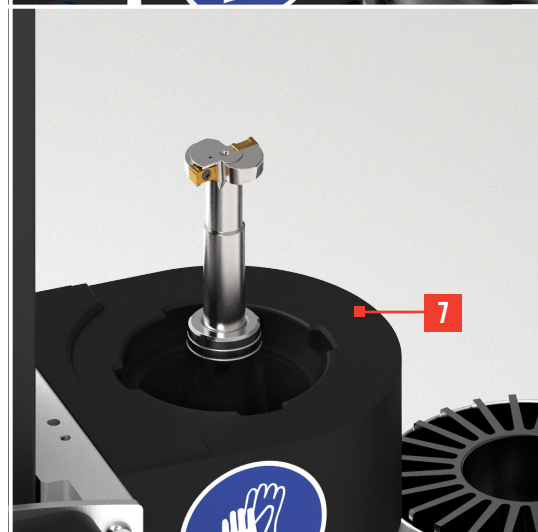



## SHRINK RELEASE OF SPECIAL TOOL HOLDERS

Move the inductor housing below the front face of the toolholder and fit the appropriate split heat-focusing stopper assembly around the shank of the cutting tool **8**.

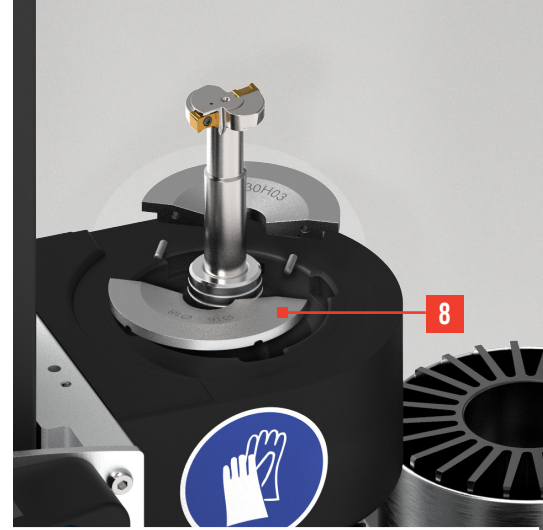

Move the inductor housing upwards so that the split heat-focusing stopper sits in the inductor housing location diameter **9** and fit the lock ring **10**.

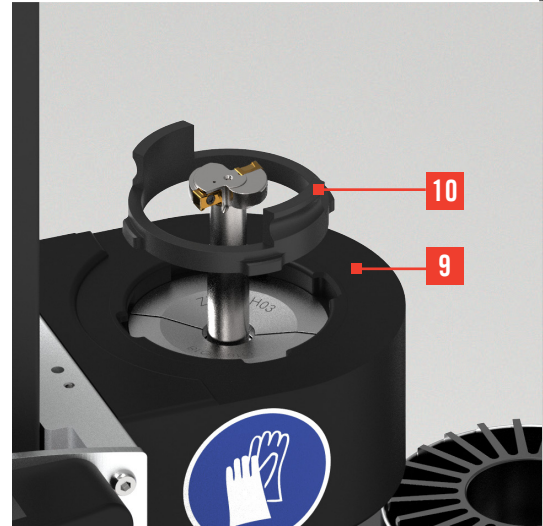

Start the heating cycle for a standard tool.



Remove the tool **11** and move the inductor housing upwards.

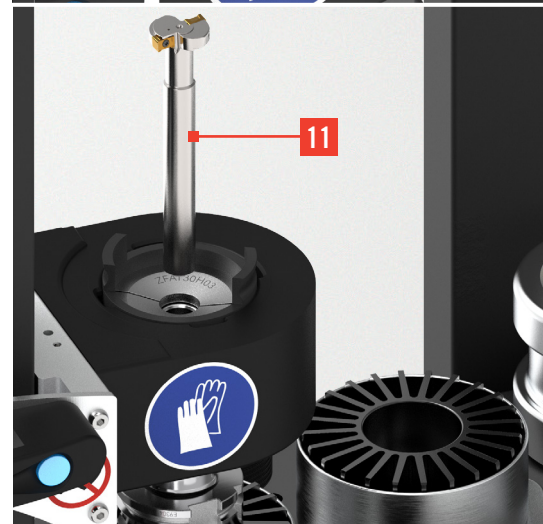

## SHRINKING CAPABILITY

SHRINKFIT HOLDER TYPE	SFR 5800	SFS 5801	SFD 5603	SFR 5600
AVERAGE SHRINKING TIME	6 sec.	2.5 sec.	4 sec.	6 sec.
MINIMUM SHRINKING Ø (TOOL SHANK)	6 mm	3 mm	6 mm	6 mm
MAXIMUM SHRINKING Ø (TOOL SHANK)	32 mm	16 mm	32 mm	32 mm
MAXIMUM Ø OF TOOL WITH FRONT END THAT IS LARGER THAN SHANK	63 mm			
AVERAGE OPEN AIR COOLING TIME	25-35 min.	15-25 min.	20-30 min.	25-35 min.
AVERAGE VENTILATOR STREAMED AIR COOLING TIME	10 min.	5 min.	8 min.	10-15 min.
AVERAGE WATER COOLING TIME	2 min.	1 min.	1.5 min.	2 min.

## SHRINKING/UNSHRINKING OF CUSTOM TOOL HOLDERS OR COMPETITOR'S TOOL HOLDERS

The Easyshrink Evo offers the possibility to set up manual heating programs by using a dedicated web interface.

Please contact your usual Seco partner for detailed information.

# MAINTENANCE FREQUENCY

## 1. DAILY MAINTENANCE

- Clean the device.
- Control the correct running and good condition of the device.

**1** Check the condition of the inductors.

**2** Check the condition of the heat-focusing plates.

**3** Check the condition of the stop rods.



## 2. MONTHLY MAINTENANCE

**4** Check the water level of the water-cooling unit.

**5** Check the water temperature.



**In the case of significant condensation, it is advisable to slightly increase the water temperature to prevent condensation on the bells and the tool holder.**



## 3. TWICE A YEAR

The water-cooling unit must be drained off.

Turn off the general power supply by pressing the switch at the back of the device.



Open the lid on the top of the water-cooling unit (4 screws to be removed).



Simultaneously pull the 2 white pull studs in opposite directions in order to open the tank then empty the tank.

**Wastewater is considered to be polluted and must be treated according to environmental constraints.**

**Fill the tank up with pure tap water** until the indicated level is reached ( $7.5 < \text{pH} < 9 / 7^\circ\text{C} (44.6^\circ\text{F}) < \text{TH} < 15^\circ\text{C} (59^\circ\text{F})$ ).

Close the tank again, replace the lid and screw it back.  
Switch on the general switch at the back of the device.

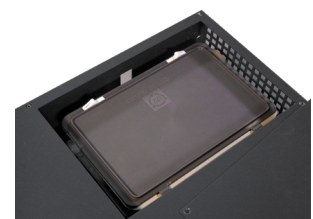

## SAFETY PRECAUTIONS

This shrinking device is only intended for professional use.

Take care to use the correct power supply:

The device only accepts the voltage AC 3 x 400 V (+/-10%) + PE/28 A/50 Hz

For other voltages the use of a ZFM30IN30 transformer is required, which needs to be bought separately:

- Input voltages: 3 x 208 / 240 / 480 / 600 VAC + GND/28 amp/50-60 Hz
- Output voltages: AC 3 x 400 V + PE/28 A/50 Hz

The power supply for the refrigeration unit is: 1 x 230 V + PE/16 A/50-60 Hz.

The Shrinkfit holder becomes very hot during operation. Touching this spot may cause serious burns. Always wear gloves when handling Shrinkfit holders.

Persons with medical implants are not permitted to use or work with this device. Persons with pacemakers must refer to the guidelines of their pacemaker established on the basis of: NF EN 60601-1-2 (September 2007).

Repairs to the shrinking devices should only be carried out by skilled operators. Please contact your Seco Sales Unit.

Only trained and authorized persons are permitted to use the shrinking devices.

## RECOMMENDATIONS FOR USE AND MAINTENANCE

Always make sure the holder has cooled down prior to shrink grip or shrink release.

The holder and the tool must be clean, free from grease and dry before being fitted to the device.

Before starting the shrinking process, please always check if:

- The power supply is sufficient
- The length has been set correctly, with the correct stop rod
- The correct heat-focusing stopper has been chosen
- Recommended cylindrical tool shank tolerance is h5 or h6 (maximum h5 for Ø3 (Ø0.118") to Ø5 mm (Ø0.196"), maximum h6 for Ø6 (Ø0.236") to Ø32 mm (Ø1.26"))
- The tool shank is not damaged

Keep the device and its environment clean to ensure a long service life.

The device can only be used for the purposes defined in this operating manual. Seco Tools Tooling Systems cannot be held responsible for casualties caused by any other use.

Maintenance is limited to regular cleaning of the device and accessories with adapted products.

## SAFETY FUNCTIONS OF THE HEATING MODULE

- The inductor is equipped with a sensor to avoid overheating of the holders and if the temperature limit is reached the Interface will be not available.

- To increase the service life of the holders, the electronics of the device have been programmed to allow only one main heating process, which it automatically cuts off after use.

## ANNEXES

Technical features

Compliance declaration for heating modules, support and cooling boxes (to fill in)

Certificate

# TECHNICAL FEATURES

## Easyshrink Evo:

Voltage	3 x 400 V(+/-10%) + PE
Power	10 000 VA
Frequency	50-60 Hz
Weight	46.2 kg (102 lbs)

	TEMPERATURE	AIR HUMIDITY	AMBIENT AIR PRESSURE (3)
USAGE	10 to 40°C (50 to 104°F)	10 to 90% (1)	800 to 1013 hPa (11.6 to 14.7 psi)
STORAGE	-20 to 55°C (-4 to 131°F)	30 to 95%	800 to 1013 hPa (11.6 to 14.7 psi)
TRANSPORTATION	-20 to 70°C (-4 to 158°F)	30 to 95% (2)	800 to 1013 hPa (11.6 to 14.7 psi)

1. Prevent condensation and frost
2. Air humidity when the temperature of the device slowly increases to 40°C (104°F) or quickly passes from -20 (-4°F) to +30°C (86°F)
3. At a maximum of 2000 m (6500 feet) above sea level

## Refrigerated water-cooling bells unit

Media to be cooled	Water
Flow rate of media	30.0 l/min 1.7 bar (24 psi)
Operating pressure max.	3.5 bar (51 psi)
Ambient temperature	10.0°C (50°F) to 35.0°C (95°F)
Refrigerant	R134a 0.310 kg (0.682 lbs)
Voltage	1 x 230 V + PE
Ext. on/off signal	24 VDC
Frequency	50-60 Hz
Power	850 VA
Weight (without water)	39.8 kg (88 lbs)



Seco Tools Tooling Systems  
F-67330 Bouxwiller  
Tel.: +33 (0)3.88.71.38.89

## UE COMPLIANCE STATEMENT

to the directives:

- 2014/30/UE " Electromagnetic Compatibility "
- 2014/35/UE " Low Voltage Directive "
- 2013/35/UE " Electromagnetic Fields Directive "

We declare that the product:

### EASYSHRINK EVO

Automatic vertical shrinking/unshrinking device  
by induction heating  
for fretting tool holders

Reference

complies with the essential requirements of the directives:

- 2014/30/UE,
- 2014/35/UE,
- 2013/35/UE.

based on the following standards:

- NF EN 61000-6-2 (January 2006)
- NF EN 55011 (June 2016) A1 (June 2017)
- NF EN 60204-1 (September 2006) A1 (May 2009)
- NF EN 62311 (October 2008)

Bouxwiller, Wednesday, December 4<sup>th</sup> 2019

**Joseph Colantuono**  
Managing Director - Tooling Systems  
Product Line Director - Tooling Systems  
F-67330 BOUXWILLER



Seco Tools Tooling Systems  
F-67330 Bouxwiller  
Tel.: +33 (0)3.88.71.38.89

# UE COMPLIANCE STATEMENT

to the directives:

- 2014/30/UE " Electromagnetic Compatibility "
- 2014/35/UE " Low Voltage Directive "

We declare that the product:

**EASYSHRINK EVO**

Cooling module

Reference:

complies with the essential requirements of the directives:

- 2014/30/UE,
- 2014/35/UE,

based on the following standards:

- NF EN 61000-6-2 (January 2006)
- NF EN 61000-6-4 (March 2007) A1 (May 2011)
- NF EN 60204-1 (September 2006) A1 (May 2009)

Bouxwiller, Wednesday, December 4<sup>th</sup>, 2019

**Joseph Colantuono**  
Managing Director - Tooling Systems  
Product Line Director - Tooling Systems  
F-67330 BOUXWILLER



WWW.SECOTOOLS.COM

## AFTER SALES SERVICE

NOTH AMERICA  
+1 844 274 7822

CHINA  
+86 198 0103 1927

EU AND THE REST OF THE WORLD  
+41 27 92 04 55

[easyshrink@secotools.com](mailto:easyshrink@secotools.com)

**SECO TOOLS**  
**TOOLING SYSTEMS**  
**8 B RUE DE NEUWILLER**  
**67330 BOUXWILLER - FRANCE**

10115449 - 60EASYEVO\_GB10

© SECO TOOLS AB, 2022.

All rights reserved. Technical specifications are  
subject to change without notice.



Follow us on our social media channels.